

SAILOR H4122 Iridium Ship Security Alert System



Introduction

Thank you for choosing our equipment and Congratulations on Your new Iridium Ship Security Alert System. We hope everything has been delivered correctly and to Your satisfaction.

In order to get the maximum performance and Radio survey approval of Your new Iridium Ship Security Alert System, please note and follow the installation guidelines precisely.

The Iridium Ship Security Alert System is an add-on unit connected to the Iridium Transceiver. All messages from the unit are transmitted through the Iridium transceiver. Messages are only transmitted, if the Iridium transceiver has an Iridium subscription and a valid SIM-card inserted.

Please make sure Your subscription is OK, before testing the Iridium Security Alert System.

About this Manual

This manual is for the daily user of the system. Additionally, it includes a section on the installation procedures. **We highly recommend you to read the manual *before* you start using the equipment.**

Disclaimer

Any responsibility or liability for loss or damage in connection with the use of this product and the accompanying documentation is disclaimed by Thrane & Thrane. The information in this manual is provided for information purposes only, is subject to change without notice, may contain errors or inaccuracies, and represents no commitment whatsoever by Thrane & Thrane. This agreement is governed by the laws of Denmark.

Manuals issued by Thrane & Thrane are periodically revised and updated. Anyone relying on this information should satisfy himself/herself as to the most current version. Providers with access to Thrane & Thrane's Extranet may obtain current copies of manuals at: <http://extranet.thrane.com>.

Thrane & Thrane is not responsible for the content or accuracy of any translations or reproductions, in whole or in part, of this manual from any other source.

Law requirement

In the requirements for Ship Security Alert Systems (SSAS) in IMO Resolution A9.24(22) and specified in the amendments (Dec. 2002) to SOLAS Chapter XI, Annex 6 the new SSAS equipment requested to be installed on the following ships were defined.

The deadline for the affected ships is:

Type of ships	Deadline for implementation
Passenger ships including high-speed passenger crafts	No later than first survey on or after July 1 st 2004
Oil tankers, chemical tankers, gas carriers, bulk carriers and high-speed cargo crafts of 500 gross tonnage and upwards	No later than first survey on or after July 1 st 2004
Other cargo vessels of 500 gross tonnage and upwards	No later than first survey on or after July 1 st 2006

** Ship status: Existing + Newbuildings*

*** ISPS CODE 2003 Edition, International Ship & Port Facility Security Code and SOLAS Amendments 2002, IMO, ISBN 92-801-5149-5*

The objective for the above mentioned regulations is to establish an international framework for detecting and assessing security threats and to take preventive measurements against security incidents affecting vessels or port facilities used in international trade.

The SAILOR H4122 complies with these regulations and is approved and certified by international classification services such as Det Norske Veritas.

Contents

Introduction	ii
About this Manual	ii
Abbreviations	1
System Overview	2
Operating - How to use the SSAS	3
Normal mode	3
Alert mode	3
Test mode	4
Iridium Tracking System	5
Connecting a PC	5
Installation	6
Technical Specification	6
System Block Diagram	8
Interfaces	9
Cable Connection Diagram	10
Connection Scheme for push Terminals	11
Cable Dimensions	11
Software Settings	11
Status and Message Log	14
Test Procedure	14
Trouble shooting	15
Parts List	iii

Abbreviations

GPS	Global Positioning System
HTML	Hyper Text Markup Language
HTTP	Hyper Text Transfer Protocol (world wide web protocol)
SIM	Subscriber Identification Module
SMS	Short Message Service
SSAS	Ship Security Alert System
ITS	Iridium Tracking System

System Overview

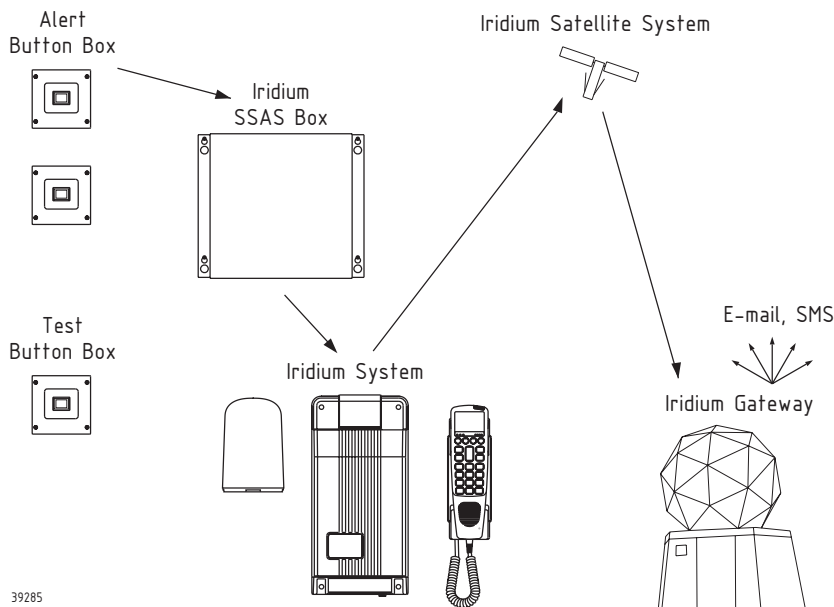

39285

In case a ship is being attacked by pirates or terrorists the crew needs a possibility to send a silent alert message to a predefined alert centre. It should be possible to activate the alert (via an alert button) from the navigation bridge and in at least one other location. Via the alert message the alert centre knows that the ship is being attacked and what the ship's position is. Immediate action can be taken to save the ship and the crew.

When the alert is activated an SMS will be sent from the SSAS system to a predefined SMS number or Email address. The test button will light green when the alert is active. Green is perceived as OK and will not indicate alert or danger.

The alert message will be sent continuously until it is reset either by the ship's crew or from land. The alert can be deactivated from land by sending a reset SMS message back to the ship.

Only in US SMS messages can be sent to a cellular phone. In the rest of the world SMS messages can only be sent between Iridium satellite phones.

The ship owner is responsible for setting up a security plan in which he specifies who shall receive the alert message and who is to be contacted.

The H4122 SSAS system consists of a SSAS control box including test and alert buttons. The H4122 SSAS system is an add-on solution to our Iridium Transceiver Unit.

The system allows the user to use the Iridium Transceiver for normal speech and data transmission.

The system has full global radio coverage. Covers A1, A2, A3 and A4 areas.

The Iridium SSAS Box will send an alert SMS/Email when the alert button is pressed for more than 2 seconds. The Iridium SSAS Box controls the Iridium Transceiver via standard AT commands.

The SSAS control unit supports a Iridium Tracking System (ITS). Via SMS or Email the shipowner will be able to follow the position of the ship. On an ITS request the system will send a pre-configured message to the recipient (shipowner) containing the latest position information, which the SSAS control unit retrieves from the GPS. The SSAS control unit can be set to automatically sending ITS messages continuously at a predetermined time interval or/and it can send a position upon a request from an incoming message with the correct password for ITS requesting.

The LAN interface on the Iridium SSAS Box supports the connection of a service PC for configuring the Iridium SSAS Box. On the Iridium SSAS Box there is an HTTP server, which holds the configuration pages made in HTML. The configuration can be used to:

- Set up Alert parameters (Email or SMS address of recipients plus choose light indicator behaviour)
- Read status log of incoming alert resets
- Download new software to the Iridium SSAS Box
- Download new HTML pages for the configuration

Operating - How to use the SSAS

Normal mode

In normal mode the system is in stand-by. It is possible to use the Iridium transceiver for normal usage (voice or data).

Data applications on a PC can be used by connecting the data cable to the PC port on the Iridium SSAS Box. See "Connecting a PC".

Power on indication

When the power is connected to the Iridium SSAS Box the system will initialise and the green light indicator will turn on. This light indicator is also used for error indication in case there is no connection to the Iridium transceiver or the GPS. See "Trouble shooting".

Test button light indication

The test button can be used as indicator for the alert status of the Iridium SSAS Box.

The behaviour of the test button can be set in 3 different modes:

NORMAL	Per default the light in the test button is off in normal mode and turns on when an alert is active
INVERTED	The light will be constantly on in normal mode and turns off when the alert is activated
OFF	Turns the light off permanently

It is recommended to use the NORMAL setting.

Iridium Tracking System

The ITS can be active in normal mode. See "Iridium Tracking System".

Alert mode

Activating the alert

Press one of the alert buttons and hold it for minimum 2 seconds. After 2 seconds the button will light up and the button can be released. Only the button, which is pressed, will light up. The light in the test button will now turn on constantly and the unit is in alert mode.

An alert message is sent immediately after pressing the alert button. Alert messages will be sent periodically until they are reset. The time between the messages can be set from 1x5 minutes to 255x5 minutes. The setting is made at the configuration page.

The message will be sent to all the predefined recipients listed in the configuration.

When an alert message is sent the SMS messages stored on the

0424

SIM card will be deleted in order to make room for receiving an alert reset SMS.

Notice:

It is possible to send alert messages and make a voice call at the same time but a data call will be interrupted when an alert is activated.

The contents of the message are shown in table 1.

Name	Format	Length	Example
Message Code*	Xxxxxxxxxxx	13	SECURITYALERT
Sequence number**	Xx	2	01
Ship Name	xxxxxxxxxxxxxxxxxxxx	20	Karaboudjan
MMSI	MMSIxxxxxxxx	13	MMSI041123456 (the 3 first digits are country code)
IMO	IMOxxxxxxxx	10	IMO1234567
Position longitude	POSDDDMM.MM,a Degrees and minutes	13	POS12258.85,W
Position latitude	DDMM.MM,a Degrees and minutes	9	3722.42,N
UTC time	TIMEhhmmss hours, minutes and seconds NMEA format without decimals	10	TIME221008
Date	DATEddmmyy	10	DATE141103
C.O.G. (Course Over Ground)	COGddd	6	COG274
S.O.G. (Speed Over Ground)	SOGx.x Knots	7	SOG08.4
System	ECI H4122	9	ECI H4122

Table 1

- *) The message code is fixed and will tell the recipients that this is an alert.
- ***) Each message gets a successive sequence number, which makes it possible to track the ship's route. The counter counts to 99 and starts over again counting from 1.

The actual SMS body of the examples in the above template will be:

SECURITYALERT,01,Karaboudjan,MMSI041123456,IMO1234567,POS12258.85,W,3722.42,N,TIME221008,DATE141103,COG274,SOG08.4,ECI H4122

Notice:

In case the GPS information isn't available the message will be sent with the data replaced by crosses (XXX).

Deactivating the alert

The alert can be deactivated in two ways. Either by pressing the test button or by sending an SMS message to the system.

Press the test button to deactivate the alert

The green light will turn off when the alert is deactivated. A message will be sent to the recipients that the alert has been deactivated and the system is back to normal mode.

Normal mode message:

NORMALMODE,<Shipname>,MMSI<number>,IMO<number>

Send an SMS to deactivate the alert

Send an SMS or Email to the Iridium Transceiver using the phone number on the SIM card. The SMS or Email message shall contain the following:

ALARMRESET,<PASSWORD>

Where the password is an 1 to 8 digit code free of choice. The password is set at the configuration page. Use capital letters.

Example:

ALARMRESET,99887766

You can send the message in three ways:

1. Send an SMS from another Iridium transceiver, which has either SMS service in the handset or via a PC with the EuroCom Industries SMS Client installed.
2. Or send an SMS from Iridium satellites homepage on the internet www.iridium.com. Chose "Send a Satellite Messages" and enter the phone number and the reset message.
3. Or send an Email from any Email client (like Outlook) by entering the Iridium phone number into the following generic address, **8816[number]@msg.iridium.com**. Enter the reset message in the text field.

When the SSAS unit receives the reset message with a valid password the SSAS unit will go back to normal mode and send a normal mode message to confirm the alert deactivation. The normal mode message will be sent to all the recipients who got the alert message.

Test mode

The test mode is used to check that the system is working properly.

The test message will contain the same information as the alert message (table 1). The only difference is the message code "TESTALERT" at the beginning of the messages.

Test messages will be sent only to the recipients listed in the configuration setup page.

"TESTALERT,MESSAGE_NUMBER,SHIPNAME,MMSI_number,IMO_number,POSITION,TIME,DATE,COURSE_OVER_GROUND,SPEED_OVER_GROUND,ECI H4122"

When the test button is pressed the Iridium SSAS Box will send 2 test messages. When the last test message is sent the Iridium SSAS Box will go back to normal mode and send a normal mode message. The time between the 2 test messages can be set from 5 minutes to 30 minutes in intervals of 5. The setting is done at the configuration page.

Before running the test procedure all communication to the PC port must be stopped since the PC data application will occupy the data bus to the Iridium transceiver.

Test procedure

1. Press the test button.
2. The green light in the test button is flashing for 10 seconds (the test can be stopped within these 10 seconds by pressing the test button again).
3. The green light lights constantly and the first test message is sent.
4. Delay (according to the setting in the configuration page).
5. The second and final message is sent.
6. The green light is flashing for 10 seconds and turns off.
7. The Iridium SSAS Box goes back to normal mode.
8. A normal mode message is sent.

Notice:

When the test mode is started it is not possible to cancel the test mode. The test sequence has to be completed before the system returns to normal mode.

Though an alert activation has always highest priority. Pressing any of the alert activation buttons will cancel the test and alert messages are sent instead.

Iridium Tracking System

With the Iridium Tracking System the SSAS control unit can send information about the ships position. There are two ways to get the position information:

Automatic ITS

Automatic ITS mode is set and enabled at the configuration page. In this mode the SSAS unit will send periodical tracking messages. The period between messages can be set from 1x5 minutes to 255x5 minutes.

ITS request

It is possible to send an SMS to the SSAS control unit to request position information.

Send an SMS or Email to the Iridium terminal using the phone number on the SIM card. The SMS or Email message shall contain the following:

ITSREQ,<PASSWORD>

Where the password is an 1 to 8 digit code free of choice. The password is set at the configuration page. Use capital letters.

Example:

ITSREQ,77347562

When the SSAS unit receives the ITS request message with a valid password the SSAS control unit will send one message with position information.

The recipients of ITS messages shall be entered at the configuration page. It is possible to send both to an Iridium telephone number and to an Email address.

Notice:

The ITS message will be send only to the recipient listed in the configuration page. It will not reply to the sender if this is different from the listed recipients.

Connecting a PC

When the Iridium SSAS Box is in normal mode the data interface of the Iridium transceiver can be used for various data applications, e.g. running the SMS PC client.

Connect a computer with a standard 9 pole RS232 serial cable to the PC port on the Iridium SSAS Box. Set PC com port to 19200 baud.

The Iridium SSAS Box will sense the data communication on the PC port and enter a transparent mode where it will forward any data to and from the Iridium transceiver.

In case the alert is activated the data communication will be stopped.

Notice:

When a PC program uses the Iridium Transceiver as a modem via the PC port on the SSAS control box the test mode can not be started. The Iridium Tracking System will not be able automatically to send neither position data nor requested position data.

Stop the PC program in order to enable the use of the test mode or the Iridium Tracking System.

Installation

Technical Specification

Input voltage: 10 – 32 VDC

Current consumption: Max. 300 mA

Operating temperature: -15 to +55 degree Celcius

Interfaces:

PC data port: RS232, 19200 baud

Iridium data port: RS232

GPS input: NMEA 0183 version 2.20 and 2.30
Following NMEA messages are supported:
GPRMC, GPGLL, GPVTG and GPZDA
Check sum is recommended

LAN: Ethernet TCP/IP 10/100Mbps

IP Class: IP22

Compass safe distance: 80cm

IMPORTANT!

The power supply for the Iridium transceiver and the Iridium SSAS Box must have a backup power in case of power failure on the ship's AC supply. This is a requirement specified by the IMO resolution MSC.147(77) section 3.1.

Dimensions and drilling plan

Iridium SSAS Box

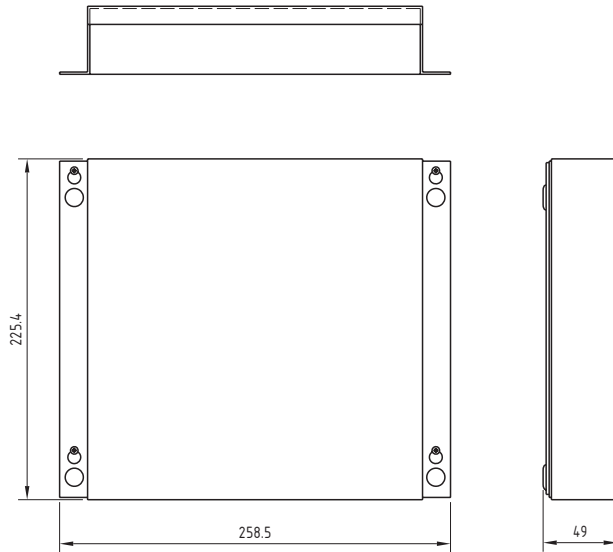

Mounting

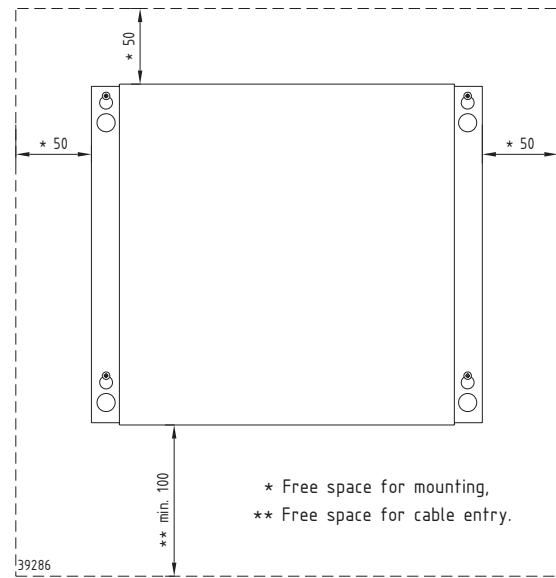

DRILLING PLAN

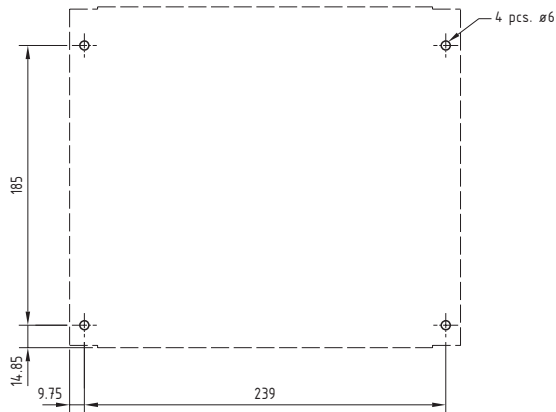

39284

Iridium SSAS Alert Button Box / SSAS Test Button Box

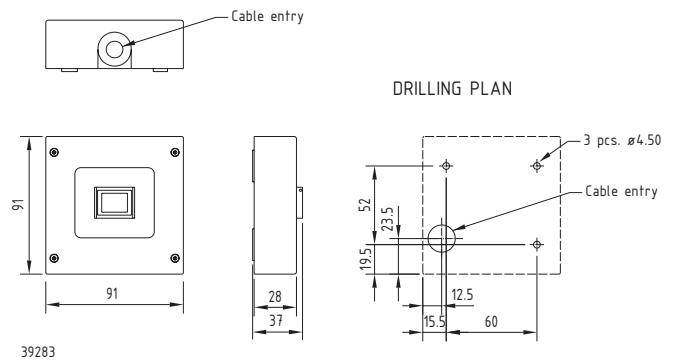

39283

Weight

SSAS Box 1.7 kg
 SSAS Alert Button Box/
 SSAS Test Button Box 0.3 kg

System Block Diagram

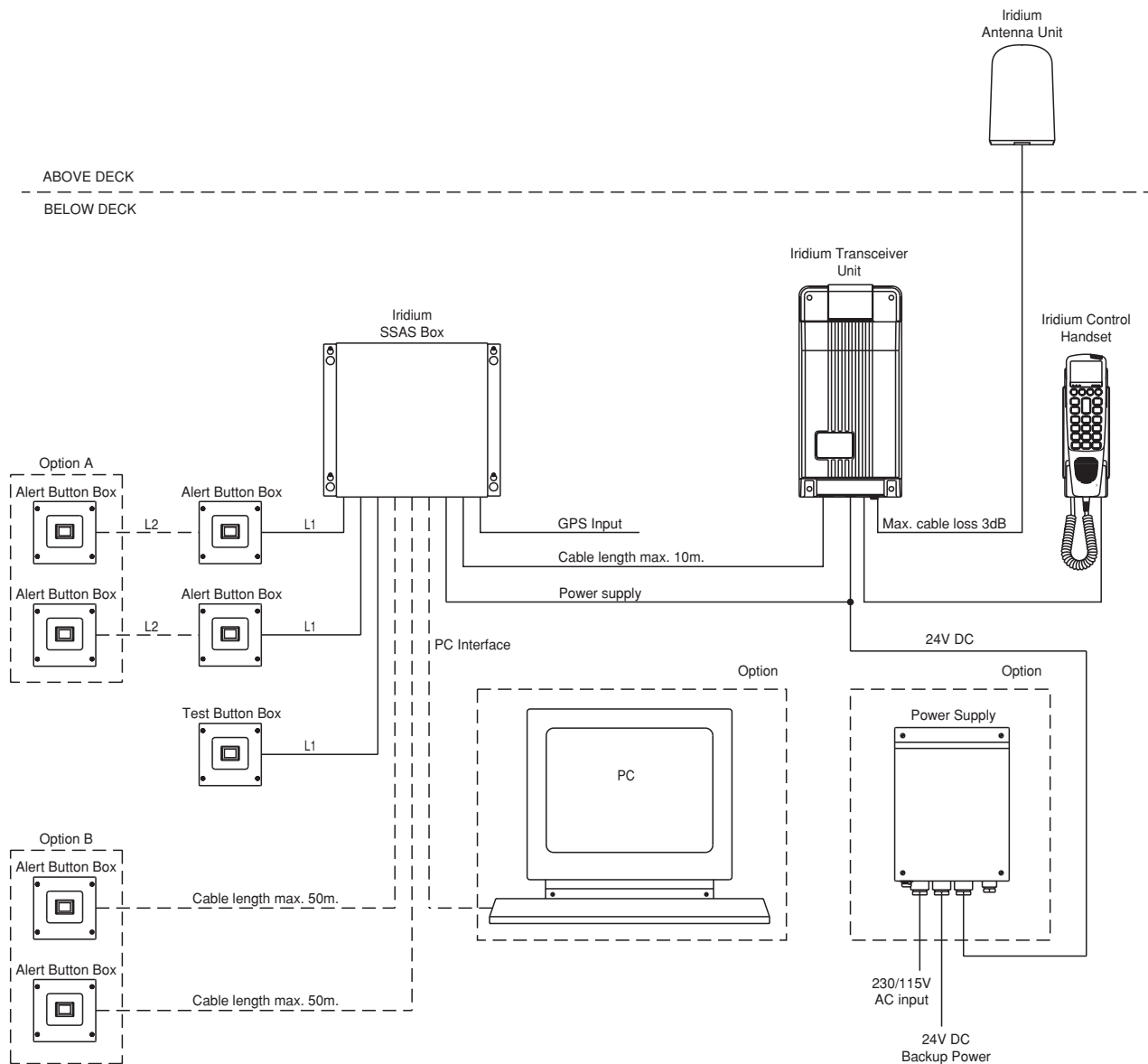

NB: Option A or option B only allowed.

L1+L2 < 50 metres

The system is made for 2 alert buttons but can handle 2 additional alert buttons by connecting them as option A or option B.

The GPS input can be taken from any device with NMEA output.

Option Power Supply - Refer to spare parts list.

39282A

Interfaces

GPS input

Connector type: 3 pole push connector

Pin:	Name:	Function:	Specification:
1	NMEA+	GPS positive terminal	RS422* galvanic isolated via optocoupler
2	NMEA-	GPS negativ terminal	RS422* galvanic isolated via optocoupler
3	REF	Reference	Ground or reference from the GPS

*) According to IEC 61162-1: Maritime Navigation and radiocommunication equipment and systems – Digital interfaces, part 1: single talker and multiple listeners

Alert Input 1

Connector type: 3 pole push connector

Pin:	Name:	Function:	Specification:
1	CNT	Contact	5V DC logical input (internal pull-up)
2	LED	Light	LED current max 30mA
3	REF	Reference	

Alert input 2

Connector type: 3 pole push connector

Pin:	Name:	Function:	Specification:
1	CNT	Contact	5V DC logical input (internal pull-up)
2	LED	Light	LED current max 30mA
3	REF	Reference	

Test button input

Connector type: 3 pole push connector

Pin:	Name:	Function:	Specification:
1	CNT	Contact	5V DC logical input (internal pull-up)
2	LED	Light	LED current max 30mA
3	REF	Reference	

Power supply

Connector type: 3 pole push connector

Pin:	Name:	Function:	Specification:
1	BAT +	Positive power line	Voltage: 10 – 32 VDC Current: max 300mA
2	BAT -	Negative power line	
3	BAT -	Negative power line	

Iridium interface (data)

Connector type: 9 pin Sub-D Male (Data Out)

Pin:	Name:	Function:
1	DCD	Data Carrier Detect (in)
2	RXD	Receive Data (in)
3	TXD	Transmit Data (out)
4	DTR	Data Terminal Ready (out)
5	GRD	Ground
6	DSR	Data Set Ready (in)
7	RTS	Request To Send (out)
8	CTS	Clear To Send (in)
9	RI	Ring Indicator (in)

PC interface (data for SSAS/SMS)

Connector type: 9 pin Sub-D Female (Data In)

Pin:	Name:	Function:
1	DCD	Data Carrier Detect (out)
2	TXD	Transmit Data (out)
3	RXD	Receive Data (in)
4	DSR	Data Set Ready (in)
5	GRD	Ground
6	DTR	Data Terminal Ready (out)
7	CTS	Clear To Send (in)
8	RTS	Request To Send (out)
9	RI	Ring Indicator (out)

Ethernet LAN connector

Connector type: RJ-45

Pin:	Name:	Function:
1	TX+	Standard LAN
2	TX-	
3	RX+	
4	N/C	
5	N/C	
6	RX-	
7	N/C	
8	N/C	

Cable Connection Diagram

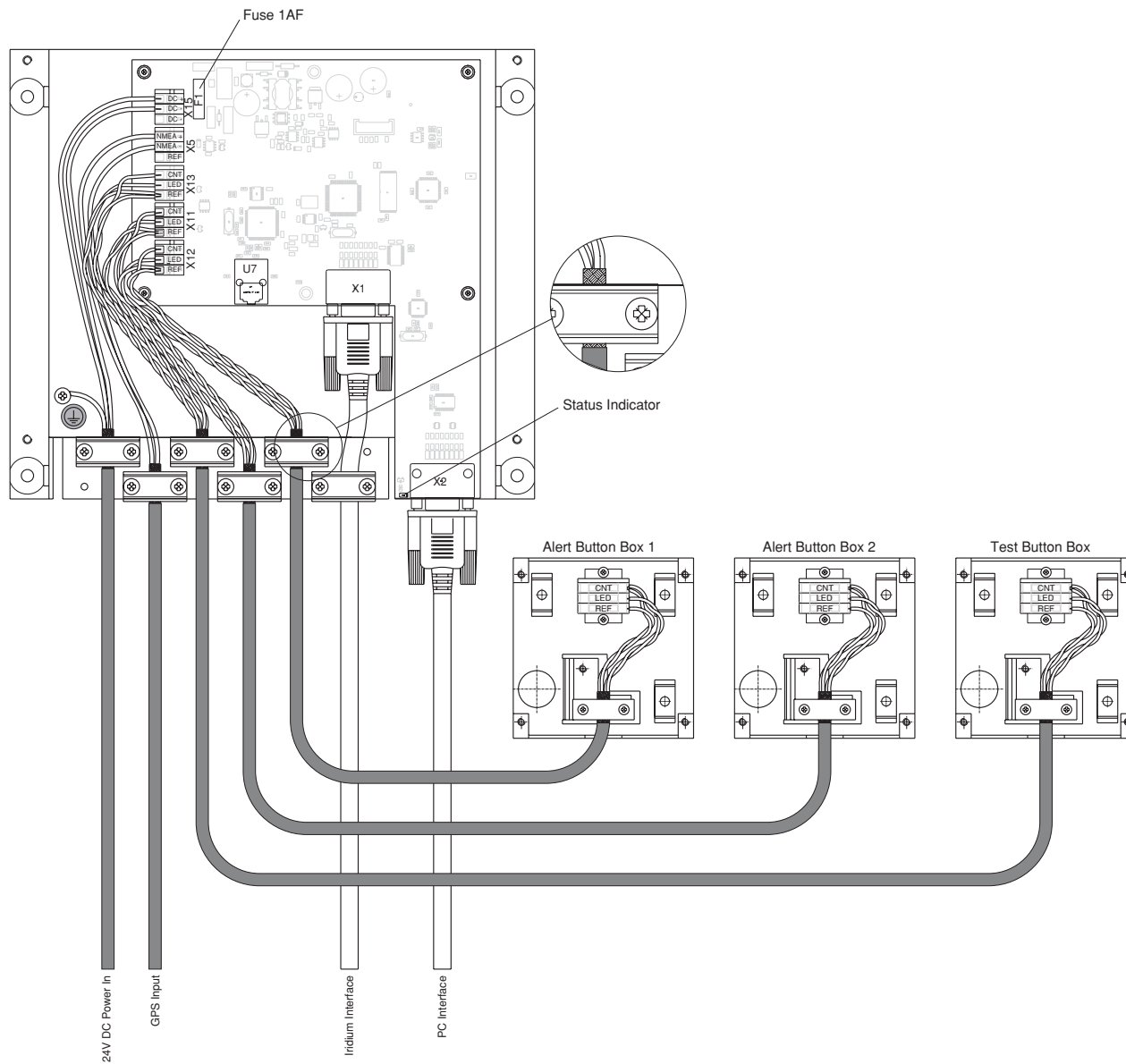

39288A

Connection Scheme for push Terminals

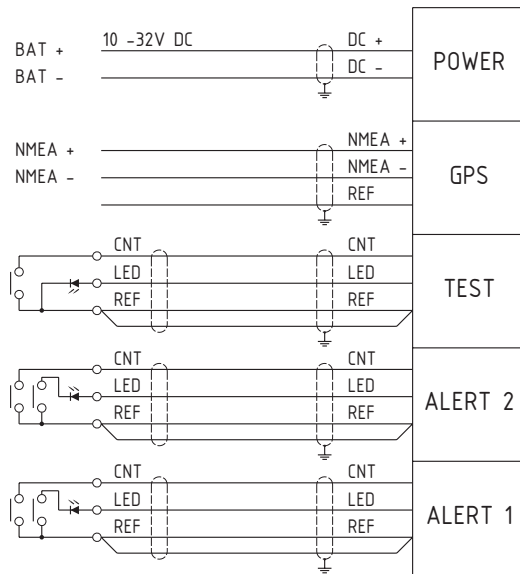

39287

Cable Dimensions

Cable for buttons 2 x 2 x 0.5mm² Twisted pair and shielded
 Cable for power supply 3 x 0.5mm²
 Cable for GPS / NMEA 2 x 0.5mm² Shielded

Software Settings

How to access the Iridium SSAS Box

The service interface is made via the LAN interface. The Iridium SSAS Box has an HTTP server with its own web pages for configuration, status and software upgrading.

The Iridium SSAS Box has its own IP and MAC address.

The Iridium SSAS Box default IP parameters:

IP address: 192.168.2.40
 Subnetmask: 255.255.255.0
 Default gateway: 0.0.0.0

The IP address can be changed to fit any other local network. When changing the IP address you must make sure to write down the new addresses on the IP Address Label

IP adr: _____

Subnet mask: _____

Gateway: _____

 EuroCom Industries A/S, Denmark

The IP address can be set back to default by switching off the power from the Iridium SSAS Box and pressing down the test button when power is switched on again. (The Test button terminal on the board can be short-circuited during power up).

Connecting a PC to the LAN

Using a cross cable, HUB or switch:

The network settings on the computer must be set to same logical net as the Iridium SSAS Box. The node number must be set differently from the Iridium SSAS Box. The subnet mask must be the same.

How can I see or change the PC IP address?

This description applies only for windows operating systems win95/98/ME.

A PC stores the IP address in the Network Neighbourhood settings. To see the PC IP address, right click on the Network Neighbourhood icon on the desktop. Select the Configuration tab, scroll down the list of network components and select the TCP/IP protocol associated with the computers network card. Note that in the example below,

there are several TCP/IP protocol installed. You can ignore the ones that have “Dial-Up” in the name associated with an internet service provider. In this example, the TCP/IP protocol associated with the 3Com LAN network card has been selected.

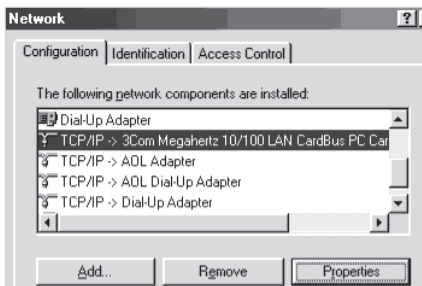

Click on the Properties button, select the IP Address tab. The IP address and the subnet mask are displayed.

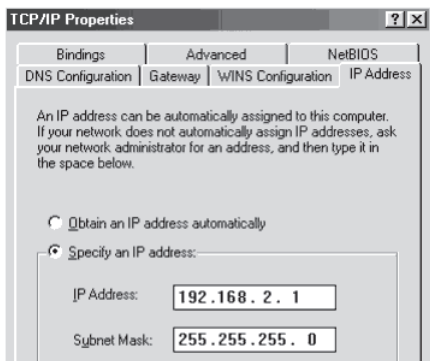

Enter the IP address/subnet mask according to the figure above, and click **OK** to save the new IP address specification.

To get in contact with the web pages on the Iridium SSAS Box any Internet explorer program can be used.

Write the address for the Iridium SSAS Box in the search field:

http://192.168.2.40

and press Enter or Search.

Now the Index page of the Iridium SSAS Box is shown.

If not then check the Internet settings and disable proxy server if this is set. The proxy settings can be found under – Functions – Connections – LAN settings.

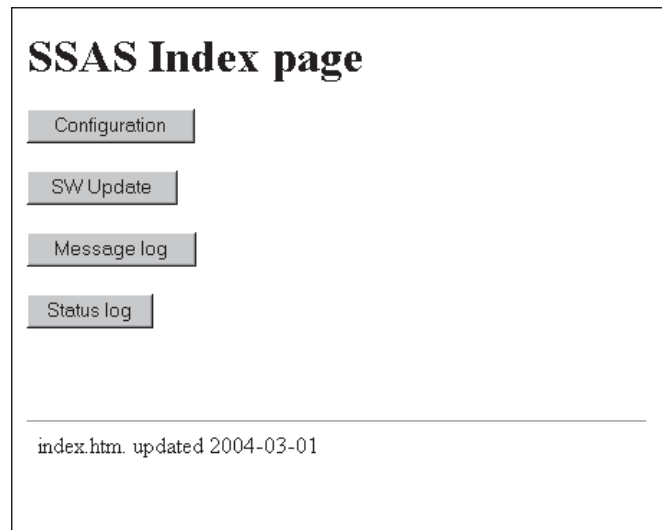

Configuration parameters

Parameter	Range	Default value	Description
Message configuration			
Email address length:	Max 25/50 chars	25 chars	Max limit for Email length can be set. Choosing 50 char will automatically remove COG, SOG and "system" from the message. When disabling one or more fields the additional text field will be enabled.
Ship's Name	ON OFF	All ON	
MMSI number			
Course Over Ground			
Speed Over Ground			
System Info			
Ship's Name	Max 20 chars		Ship's name
MMSI number	Max 10 digits		Ship identification number
IMO number	Max 7 digits		International Maritime Organisation number
Additional text	0-60 chars		User specific text can be entered here when other parameters are disabled via the message contents field. The remaining number of characters can be viewed by enabling the status bar in the web browser.
SMS Service Centre Phone Number	Max 20 digits	00881662900005	The Service Centre number for the Iridium gateway.
ITS Phone Number	Max 20 digits		The number to which SMS ITS messages shall be sent
ITS Email	Max 25/50 chars		The Email address to which SMS ITS shall be sent
Alarm Phone Number 1	Max 20 digits		The number to which Alarm SMS messages should be sent
Alarm Phone Number 2	Max 20 digits		The number to which Alarm SMS messages should be sent
Alarm Email 1	Max 25/50 chars		The Email address to which Alarm messages should be sent
Alarm Email 2	Max 25/50 chars		The Email address to which Alarm messages should be sent
Test Phone Number 1	Max 20 digits		The number to which Test SMS messages should be sent
Test Phone Number 2	Max 20 digits		The number to which Test SMS messages should be sent
Test Email 1	Max 25/50 chars		The Email address to which Test messages should be sent
Test Email 2	Max 25/50 chars		The Email address to which Test messages should be sent
Alarm button light	ON OFF	ON	Whether or not the light pulses in the alarm button should be shown
Test button light	OFF NORMAL INVERTED	NORMAL	Configuration of the light in the test button
Alarm interval	1,...,255 [*5 minutes]	3	How often should the Alarm SMS be sent
Test interval	1,...,6 [*5 minutes] Max 30 minutes	1	How often should the Test Alarm SMS be sent
Alarm password	Max 8 digits		Password which should be included in the Alarm reset messages
ITS Password	Max 8 digits		Password which should be included in the ITS messages
ITS Continuous	ON OFF	OFF	Enable continuous ITS messages to be sent to ITS number at a time interval
ITS Interval	1,...,255 [*5 minutes]	5	Time interval for continuous ITS message
IP address	IP Address	192.168.2.40	
Subnet address	IP Address	255.255.255.0	
Default gateway	IP Address	0 . 0 . 0 . 0	
Ethernet speed	Auto/10/100Mbit	Auto	The Ethernet speed

Notice:

Phone numbers must include the country code.
Either 0088 or +88.

Status and Message Log

Status log

A status log is maintained in the Iridium SSAS Box to provide information to the user about failed connections to the GPS and the Iridium Transceiver. The status log stores the last 10 registered failed connections.

The information for each registration is: Date, time and a description e.g.:

"19-11-2003 15:55 No contact with Iridium".

If date and time are not available then X is shown instead e.g.:

"xx-xx-xxxx xx:xx No contact with Iridium".

The status log can be retrieved via the Service PC as a HTML page.

Message log

A message log is maintained in the SSAS control unit to provide information to the user about the incoming SMSITSPollReq and SMSAlarmReset messages.

The message log stores the last 10 registered message of each type.

The information for each registration is: Date, time, description and phone number e.g.:

"19-11-2003 13:09 SMSAlarmReset received from phone number +88 10 31 01 23 45".

If date and time are not available then X is shown instead e.g.:

"xx-xx-xxxx xx:xx SMSAlarmReset received from phone number +88 10 31 01 23 45".

The message log can be retrieved via the LAN interface as a HTML page.

Test Procedure

To test that the installation is successful the following procedure must be followed.

The test is done by sending messages to an Email address. Any Email address can be used i.e. your own or e.g. the ship owners office.

If the ship has Email access you can use this with better result since you can verify the message your self.

When using a remote Email address you shall have someone helping you at the recipient end.

Step 1

Connect the Ethernet LAN cable to the RJ45 connector on the Iridium SSAS Box.

Step 2

Set up the configuration table in the Iridium SSAS Box to have only one recipient. Type the Email address in the field "Alarm Email address 1"

Press the button "configure SSAS"

Step 3

Press the first alert activation button for minimum 2 seconds.

Check that the light in the test button turns on or off according to the settings.

Step 4

Press the test button for resetting the alert.

Check that the light in the test button turns on or off according to the settings.

Step 5

Check that the Security Alert and Normal mode messages have been received at the recipient. You can check the messages on the ship Email client or you can call the recipient to confirm the delivery. Check that all details in the Security Alert message are correct.

Step 6

Press the second alert activation button for min. 2 seconds.

Check that the light in the test button turns on or off according to the settings.

Step 7

Press the test button for resetting the alert.

Check that the light in the test button turns on or off according to the settings.

Step 8

Check that the Security Alert and Normal mode messages have been received at the recipient. You can check the messages on the ship Email client or you can call the recipient to confirm the delivery. Check that all details in the Security Alert message are correct.

The system test is completed.

After the test the E-mails and phone numbers for alert recipients shall be entered at the configuration page.

IMPORTANT:

It is the ship's commanding officers responsibility that the system is checked with respect to the recipients of alarm messages. Run the test mode and check with the recipients that they have received the 2 test messages and 1 normal mode message.

Trouble shooting

The status LED on the Iridium SSAS Box will flash in case the communication with the GPS or the Iridium Transceiver fails. (Refer cable connection)

Slow flashing: No contact with Iridium transceiver unit

Fast flashing: GPS signal is missing or the check sum is wrong

Factory reset

The SSAS control box can be reset by removing power from the Unit.

Press the test button while applying power again.

All configuration parameters will be set to default and the user settings are lost.

Possible problems

The alert is activated and the status LED is flashing slowly to indicate that there is no contact to the Iridium transceiver. The alert mode cannot be deactivated.

- The service centre number may be wrong for which reason the Iridium transceiver cannot be initialised.
- Make a factory reset.

It is not possible to get in contact with the Iridium SSAS Box via the LAN interface. The IP address is forgotten.

- Make a factory reset.
IP address is now 192.168.2.40

Test mode will not start when pressing the test button.

- Check whether a serial data cable is connected to the PC port and whether a PC program is using the PC port. Stop the PC program and press the test button again.

Can not receive SMS on a GSM mobile phone.

- Only in US SMS messages can be send to a cellular phone. In the rest of the world SMS messages can only be send between Iridium satellite phones.

Parts List

NAME

PART NO.

Main Units

SAILOR H4122 Iridium SSAS Box 8041220006
Data cable 3m, 9 poles D-Sub – male/female for connection to PC 56.171

Optional

H4125 Iridium SSAS Alert Button Box 8041250206
H4126 Iridium SSAS Test Button Box 8041260206
SAILOR N163S AC/DC Power Supply, Blackgrey 80119410

Accessories

ATO Blade Fuse 1AF 45.657
Cable for buttons 2 x 2 x 0.5mm2 – twisted pair with shield
(specify length when ordering) 77.176

B4122GB0

Issue: G/0625